



# LIGHT TOOLS WITH HIGH PRECISION ASSORTIMENT 2021

 **Screwdriving technology**

 **Workspace Organisation**

 **Safety & Ergonomics**

  
**AWP**  
Your Assembly Workspace Partner

# AUTOMATIC INDUSTRIAL CORDLESS BRUSHLESS • TORQUE BATTERY SCREWDRIVERS SERIES



## External Dimension

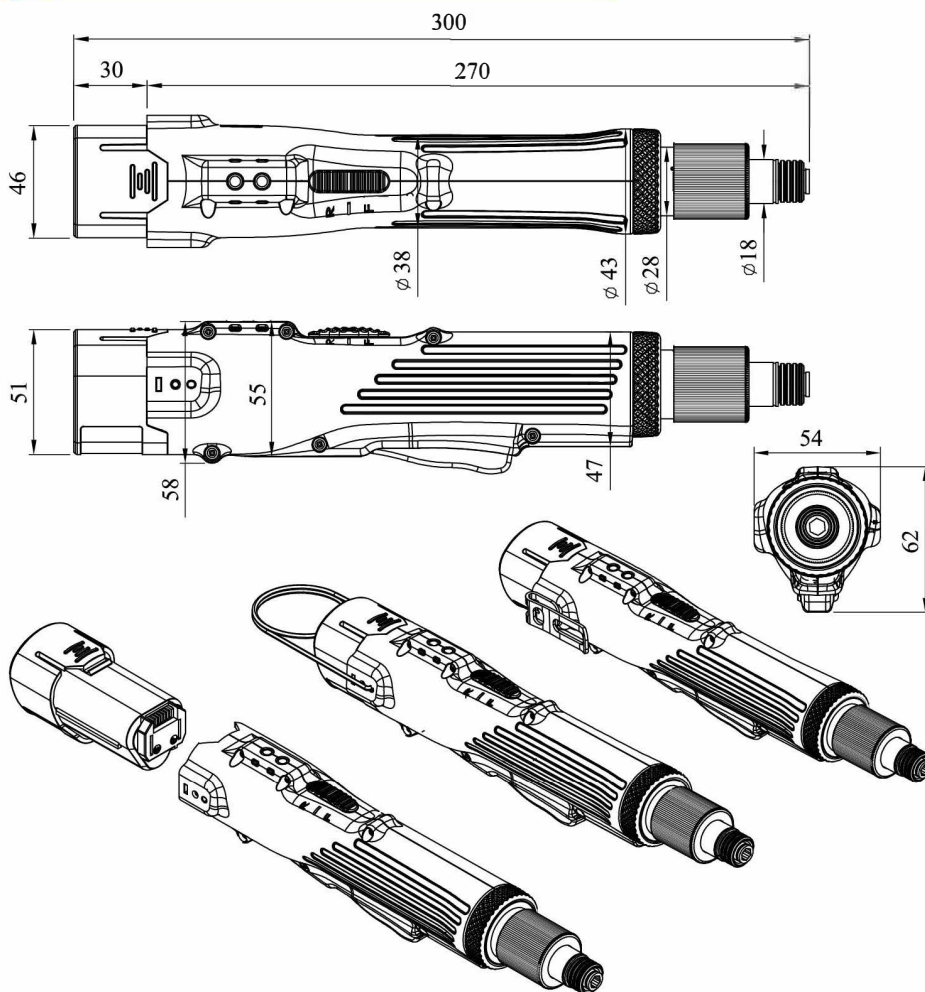

## Product Features

- The high power brushless motor has 2 years warranty.
- The best choice of industrial assembly tool which can set the maximum torque up to 4.5 N.m, and the repeatable torque accuracy within  $\pm 3\%$ .
- The cordless battery screwdriver has built-in indicating light to indicate the fasten procedure during operation. The green LED will light up and give a short beep for every fastening screw. Conversely, the red LED will light up if the screw is fastened incorrectly or NG.
- Users can select HI/LO speed via the electrical switch to meet the operation requirement.
- Excellent ergonomic design, in order to hold the cordless battery screwdriver comfortably.
- In order to extend battery operating time, the cordless battery screwdriver will turn to sleep mode automatically when it idled over 3 seconds. Sleep mode helps to save power and extend battery life time.

## Specifications

Model	ST2	ST3	ST4.5
Input Voltage	10.8V		
Torque (N.m)	0.3~2.0	0.8~3.0	1.5~4.5
Repeatable Torque Accuracy )	$\pm 3\%$		
Torque Adjustment	External Stepless		
Free Speed (r.p.m) $\pm 10\%$	HI	1200	700
	LO	850	500
Weight (kg)	0.7 (Without Battery)		
Size (mm)	270 * 60 (L * H Without Battery)		
With Battery			
With Charge Station			
With Torque Meter			
Applicable Bit Type			

## Features :

- 1 High Accuracy Assurance:** 3% deviation of torque (Shut off type), assure the best quality.
- 2 Economy:** Wide-ranging torque with longer life cycle of motor (2 years Motor guarantee for shut off type).
- 3 Dormancy Mode (Power saving):** Once the screwdriver idles for over 3 second, it will turn to dormancy mode to save the energy and increase the standby time.



# HANDY AUTOMATIC INDUSTRIAL CORDLESS SCREWDRIVER BRUSHLESS LOW TORQUE

## PISTOL Series



### External Dimension

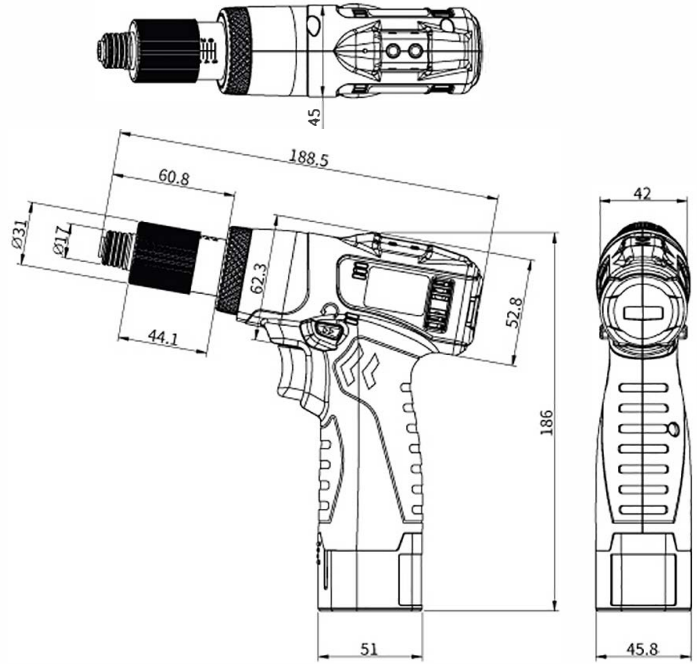

Unit: mm

### Product Features

- Compact light weight ergonomic design.
- Cleaner quieter maintenance free brushless motor.
- Most ideal for areas where cables and hoses impede handling flexibility i.e. car interior electrical cabinet interiors. trains.
- 10.8V Lithium-ion battery.

### Accessories



### Torque Range Reference Chart

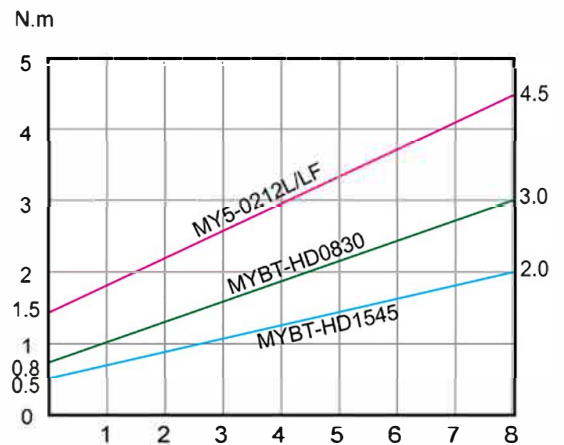

### Specifications

Model	Input Voltage	Torque(N.m)		Repeatable Torque Accuracy(%)	Free Speed (r.p.m)		Weight (kg)	Size (mm)	With Battery	With Charger	Bit Type
		Hard Joint	Soft Joint		HI	LO					
PIST-0320	10.8V	0.5-2.0	0.5~1.6	±3%	2700	1900	0.7	189X157	*	*	A · B · B9.5
PIST-0830	10.8V	0.8-3.0	0.8-2.4	±3%	1400	1000	0.7	189X157	*	*	A · B · B9.5
PIST-1545	10.8V	1.5-4.5	1.5-3.6	±3%	800	550	0.7	189X157	*	*	A · B · B9.5

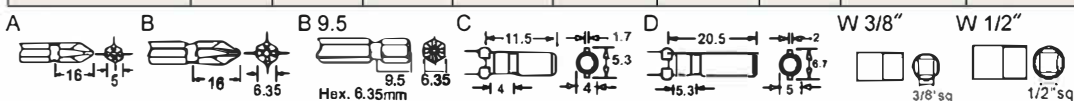

※ Tool Weight & Size indications without battery.