

MINIMAT-ED Digital Electric Screwdriver

Straight handle design: torque ranges between 0.24 - 4.8 Nm

- flexible
- economical
- comfortable
- process reliable
- robust

A good team:

The MINIMAT-ED handheld screwdriver, combined with the ComCenter ED, is the ideal solution for a wide range of applications.

The upgraded ComCenter ED has impressive new features alongside the tried and tested characteristics of the handheld screwdriver which remain unchanged.



MINIMAT-ED Handheld Screwdriver and ComCenter ED - A Great Team!

The powerful MINIMAT-ED is available in three versions for torques between 0.24 to 4.8 Nm at speeds of 1500 rpm. The speeds can be individually adjusted up to the maximum speed for each screwdriver type. The handheld screwdriver also benefits from a particularly slim design and is comfortably lightweight.

The MINIMAT-ED is recommended for a wide range of applications, particularly for workplaces with varying tightening parameters. There are opportunities for use in controller and control cabinet installations, in reworking stations, in series production or in repair facilities.

Advantages:

- **Flexible** – The required torque can be set directly on the screwdriver by the push of a button.
 - **Economical** – Attractive purchase price and compact size due to the fully integrated controller.
 - **Ergonomic**
 - End value displayed on the screwdriver
 - Trigger-start or push-to-start
 - Adjustable search run
 - Speed for each step is adjustable
 - Programming using tablet/smartphone via ComCenter ED
 - **Process reliable**
 - Torque precision
 - Password protected against unauthorized changes to the preset parameter
 - **Robust** –
As robust as all DEPRAG MINIMAT screwdriver series: absolutely reliable and renowned for durability. The brushless drive enables high performance with low maintenance requirements.
- Integrated quick change chuck for easy bit/socket exchange
 - Suspension hanger for balancer hookup
 - Low noise level
 - Ergonomic design
 - Flexible power cable
 - Good/Bad cycle indication by LED lights red/green
 - ESD-safe
 - Integrated diagnostics



The MINIMAT-ED is reliable, has an extremely long life-span and very high torque precision.

Description of functions

There are five screwdriving procedures stored in the screwdriver, each with identical three stage basic structures:

- Search run
- Screw assembly to torque
- Screw assembly/disassembly to angle

The screwdriving levels can be activated or deactivated individually making variations of the screwdriving procedures possible. By setting the parameters of speed, shut-off torque and shut-off angle the screwdriving program can be adapted to each screw assembly. From each screwdriving program you can switch directly to the associated loosening program using the reversal switch. Select the torque mode to set the preferred version of the torque adjustment. This can either be done by switching between the max. five adjustable screwdriving programs or through the quick change of the shut-off torque in screwdriving program 1.

Additional advantages of the MINIMAT-ED are the ergonomic grip design, the hanger for the balancer and the integrated quick change chuck for simple tool changes.

ComCenter ED - now with new features

The ComCenter ED enables user-friendly parameterisation of screwdriving programs using the web interface. The integrated input/output port can now also be used to select MINIMAT-ED screwdriving programs. In addition, an external start release of the screwdriver is available. The main advantage: If this function is activated, the handheld screwdriver can be used in combination with other products or a higher-level PLC.

This value-for-money option presents attractive opportunities. One example is combination with a position control stand (PKS). Only when the screwdriver has reached the right position is the correct screwdriving program selected and the start approval given.

Furthermore, there is the option of use in applications where sensors are used for supervision, such as in the detection of components, pick-and-place procedures or the use of a toolbox or scanner.

Your advantages:

- **flexible**
- **low cost solution**
- **for varying tightening parameters**
- **upgraded communication**



SYSTEM COMPONENTS

MINIMAT-ED SCREWDRIVER, Straight handle design, size 36

Screwdriver	Type	330EG36-0012	330EG36-0018	330EG36-0032	330EG36-0048
	Part no.	440000A	440000B	440000E	440000C
Torque min.	Nm / in.lbs	0.24 / 2.1	0.36 / 3.2	0.64 / 5.66	1.0 / 8.85
Torque max.	Nm / in.lbs	1.2 / 10.6	1.8 / 15.9	3.2 / 28.3	4.8 / 42.5
Speed	rpm	1500	1500	1200	900
Diameter	mm / in.	36 / 1.4	36 / 1.4	36 / 1.4	36 / 1.4
Length	mm / in.	290 / 11.3	290 / 11.3	290 / 11.3	290 / 11.3
Weight	kg / lbs.	0.75 / 1.65	0.75 / 1.65	0.75 / 1.65	0.75 / 1.65
Noise level	dB(A)	63	63	65	65
Internal hex drive DIN ISO 1173		F6.3 (1/4")	F6.3 (1/4")	F6.3 (1/4")	F6.3 (1/4")
Suitable inserting tools and connection parts with inserting end DIN ISO 1173		E6.3 (1/4")	E6.3 (1/4")	E6.3 (1/4")	E6.3 (1/4")

Required accessories

Motor cable	length 2 m/6.6 ft.	Type	Part no.	KS4-2M	151515A
alternatives					
Motor cable	length 5 m/16.5 ft.	Type	Part no.	KS4-5M	151515B
Motor cable	length 8 m/26.4 ft.	Type	Part no.	KS4-8M	151515C
Motor cable	length 10 m/33 ft.	Type	Part no.	KS4-10M	151515D
Power unit			Part no.	NG20-ED	102767A
Power supply cable (EU)	length 2 m/6.6 ft.	Type	Part no.	KN-C13/EU	833790
alternatives					
Power supply cable (USA)	length 2 m/6.6 ft.	Type	Part no.	KN-C13/US	833791
Power supply cable (UK)	length 2 m/6.6 ft.	Type	Part no.	KN-C13/UK	833792
Power supply cable (China)	length 2.5 m/8.25 ft.	Type	Part no.	KN-C13/CN	832927
Power supply cable (Brazil)	length 1.8 m/5.94 ft.	Type	Part no.	KN-C13/BR	207388

Optional equipment

Toolbox	Type	TB 7
Technical data:	Part no.	398097B
Tool holders		7
Tool size	mm/in.	up to Ø 24/0.9 (AF 19)
Voltage	V	DC 24
Amperage	mA	100
Input/output interface		SUB-D 15 pin connector
Start signal		4-pin connector
Dimensions (W x H x D)	mm/in.	225 x 50 x 120 / 8.8 x 1.9 x 4.7
Weight	kg/lbs.	1.2 / 2.6
Connection cable ComCenter ED - Toolbox	Part no.	122840A (length 5 m/16.5 ft.)
Spring sleeve cpl.	Part no.	364672A
Spring sleeve cpl., with vacuum connection (in connection with finder, see leaflet: Inserting tools D3320E)	Part no.	364672C
Screwdriver adaption	Part no.	118246B
Connection cable ComCenter ED - PKS	Part no.	on demand
Software DEPRAG Operator Guidance (activation key)	Part no.	146536



Additional accessories for integration in the manual work station can be found in our brochure D3345E. For more details to the software products, please see brochure D3900E.

ComCenter ED

ComCenter ED	Part no.	103196A	including WLAN stick and connection cable to the PC
---------------------	----------	---------	---

The ComCenter ED can be connected either via Ethernet or WLAN to the network. To enable access via WLAN, the ComCenter ED can simply be set up as an Access Point on the integrated web interface. Access to settings or the creation and adjustment of screwdriving programs can therefore be carried out at any time using a smartphone, tablet or other mobile device.

Control of the screwdriver is now also possible via inputs and outputs. As soon as the I/O port is activated via the web interface, the screwdriver buttons no longer have any function, thus guaranteeing the required processing reliability. There are four inputs available for program selection as well as outputs for status messages (OK/NOT OK/READY).

ComCenter ED with older software versions can be upgraded by ordering an update (part no. 117234).



Our software solutions undergo continuous improvements. We recommend that you regularly update your software. In this way you will always receive the most up-to-date security updates, upgraded features and drivers. With the most current version of the software you can be sure that your device is optimally prepared for Industry 4.0.

SYSTEM OVERVIEW

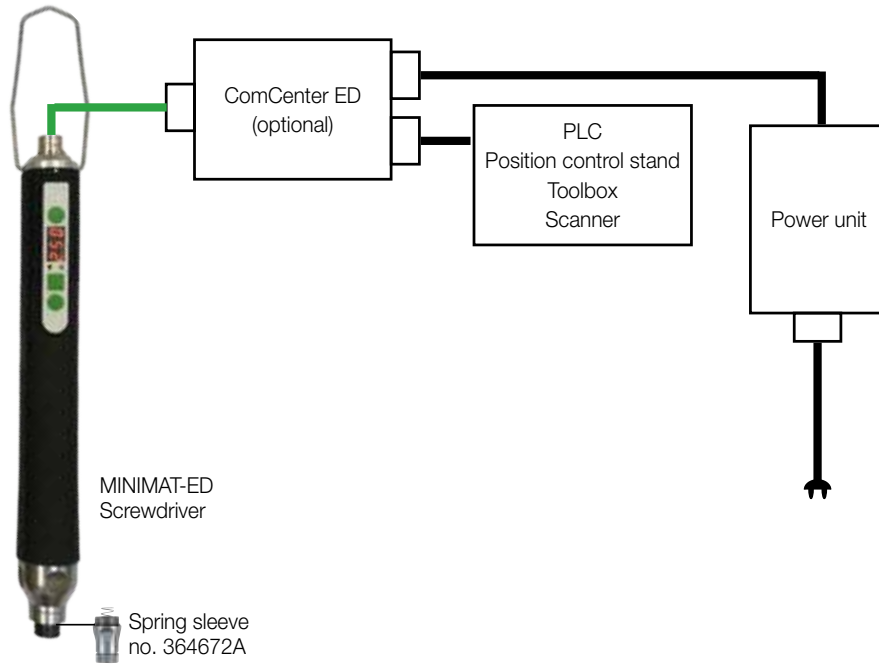

It is necessary to use a torque support (e.g. stand, handgrip) for torque: over 4 Nm for straight design and over 10 Nm for pistol grip. Suitable torque supports can be found in our brochure D3345E.

DEPRAG

DEPRAG SCHULZ GMBH u. CO.
P.O. Box 1352, D-92203 Amberg, Germany
Carl-Schulz-Platz 1, D-92224 Amberg
Phone (+49) 9621 371-0, Fax (+49) 9621 371-120
www.deprag.com
info@deprag.de

CERTIFIED AS PER DIN EN ISO 9001
